



PROJECT NAME: _____
 ITEM NUMBER: _____
 QUANTITY: _____
 LENGTH: _____

CHOICE™ SUPPORT:

- 1" OD Stainless Steel
Contact factory for additional tubing options

COMMON FINISHES:

- Brushed (#4)
- Polished (#8)
- No Smudge Silver (049/92790)
- Black Matte Fine (049/80830)
- RAL# _____
- Copper (049/63130)
- Bronze (049/66220)
- Low Light Bronze (049/61120)
- Flat Black (049/80350)
- Black Smoke Transparent (049/80375)

GLASS:

- 1/4" Glass - 48" Max. Span
- 3/8" Glass - 60" Max. Span
Contact factory for spans exceeding max.

END PANELS:

- Both (Std.)
- None
- Right Only
- Left Only

As required by NSF/ANSI 2 standards, all food shields will be quoted with side end panels unless customer requests otherwise. Standards available upon request.

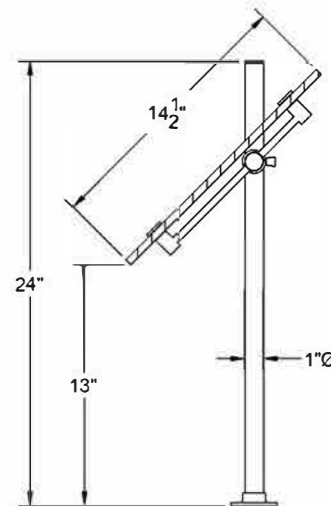
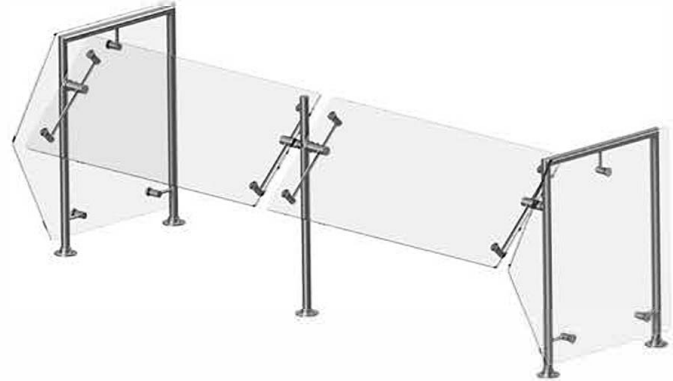

Advise counter thickness and material

SELF SERVICE ADJUSTABLE

MOUNTING OPTIONS:

Some mounting options may not be available on some cantilevered/counter substrate combinations. Refer to mounting cut-sheet or contact factory for additional information.

- 641/1 Above counter Surface Mount
- 644/1 Narrow Above counter Surface Mount
- 223 Through Counter Mount (standard when rear legs are not possible)
- 644B-3/1 Above Counter Surface Mount with Stainless Flange Cover
- Custom Mounting Options Available

ELECTRICAL COMPONENTS:

LIGHTS ONLY

- Ultra-Slim™ LED Display Light 4000k (Std.)
Ideal over refrigerated product areas

HEAT STRIP ONLY

- Hatco GRNM Narrow Max Watt Heat Lamp (Std.)^{*}
(Other Hatco heat strips available)

HEAT/LIGHT COMBO

- Hatco GRNM Narrow Max Watt Heat Lamp and Ultra-slim™ LED Lights 4000k(Std.) (with external driver)^{*}
(other Hatco heat/combo units available)

Please see electrical cut sheet for additional options and wiring diagram.

^{*}Contact factory for heat options

Specifications for reference only and may be changed without notice. All orders require approved shop drawings prior to release to production. Products are drawn and built to customer specification. It is the responsibility of the customer to ensure product meets local health board standards.

PATENT NUMBER: US 10,405,677 B2

